

Description

RS485 is perfect for transferring small blocks of information over long distances, so it is often the interface of choice. The network nodes can be PCs, microcontrollers, or any devices capable of asynchronous serial communications. Compared to Ethernet and other network interfaces, RS485's hardware and protocol requirements are simpler and cheaper.

It features 3 LED's: one indicating RS485 transmit data, one for RS485 receive data, and one for error which err lights up on 24VAC crossed.



Features

- Low cost RS485 to USB converter.
- RX and TX leds show the communications activity.
- Ground Loop LED lights up when any of the nodes has 24vac and GND crossed over.
- Self resetting fuses protect the PC from wiring mistakes in the field.
- Uses standard FTDI chip and windows drivers for any protocol and any baud rate.
- Low cost converters, permanently mount them everywhere.
- USB Powered, no separate power supply required.
- Three pin terminal for connecting to the network.
- Auxilliary jack for connecting to RJ style jacks on thermostats, etc.

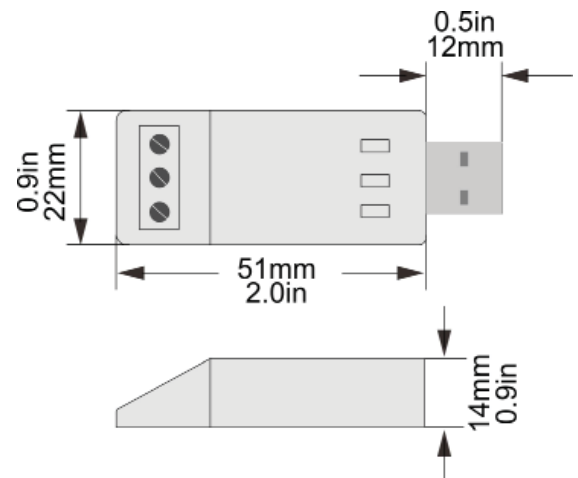

Equipment Highlights



Wiring Diagram

RS485 is a multi-drop network, it can connect tstat and controller, perfectly transferring and receiving the data. The devices can be up to 254.

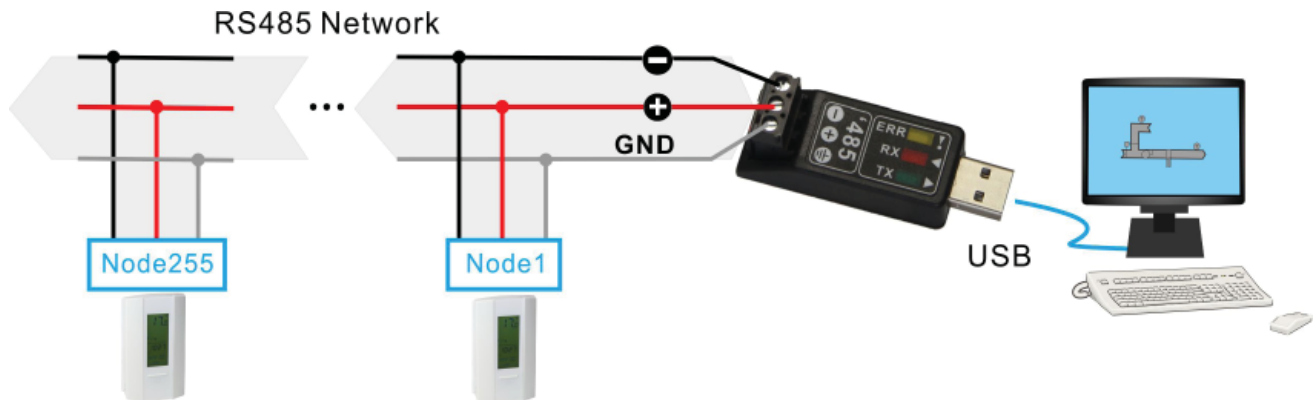

Driver Installation

Download the Driver_USB RS485 from website, here following the link.

<http://www.temcocontrols.com/ftp/software/>

- [Driver_USB-RS485.rar](#)

Schematic Diagram

